

# U7FTE80L

## | FRY-TOP ELETTRICO SU MOBILE APERTO

## | ELECTRIC FRY-TOP ON OPEN-FRONTED UNIT

### | Caratteristiche | Features



| Piastra di cottura realizzata in speciale acciaio levigato di grosso spessore | Cassetto raccogli grassi estraibile | Comandi sdoppiati per il riscaldamento differenziato della piastra | Resistenze corazzate INCOLOY a diretto contatto della superficie inferiore della piastra | Regolazione termostatica della temperatura da 100° a 300°C | Termostato di sicurezza a riarmo manuale | Lampade spia per il controllo del funzionamento | Pannello comandi facilmente estraibile per facilitare le operazioni di pulizia e manutenzione | Piedini in acciaio inox regolabili in altezza

| Cooking plate in special thick honed steel | Removable fat collecting drawer | Dual control for the differentiated heating of the plate | INCOLOY armoured heating elements in direct contact with the lower surface of the plate | Thermostatic temperature regulation from 100° to 300°C | Safety thermostat with manual reset | Warning lights for functioning control | Control panel which can be quickly removed for easy cleaning and maintenance | Adjustable AISI 304 stainless steel feet



MODELLO  
MODEL



DIMENSIONI mm  
DIMENSIONS mm



POTENZA ELETTRICA KW  
ELCTRIC POWER KW



VOLUME m<sup>3</sup>



PESO Kg  
WEIGHT Kg



ALIMENTAZIONE  
FEEDING



ALLACC. ELETTRICO  
ELEC. CONNECTION

U7FTE80L

800x730x900

9,6

0,9

110

400 V

VAC400-3N 50/60Hz

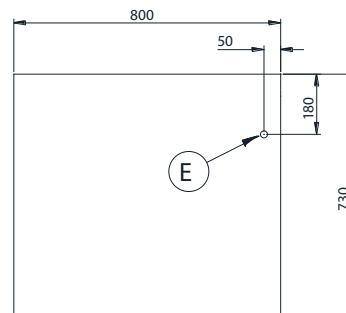
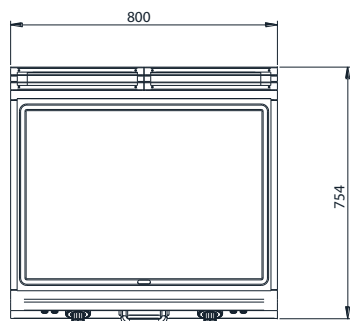
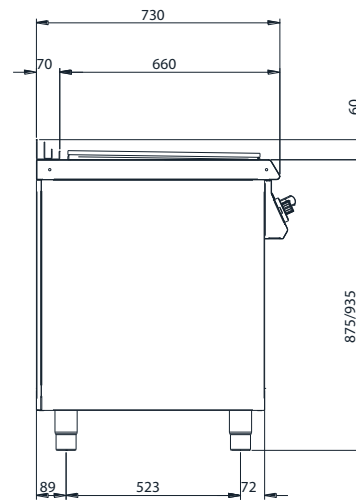
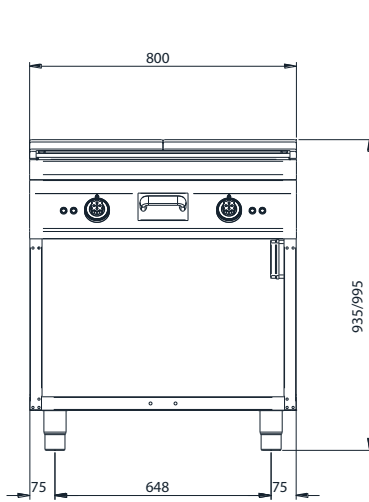

E = Allacciamento elettrico  
Electrical connection